

the breadth of interest surrounding a metal oxidation state which is thought, by a substantial fraction of practicing chemists, not to occur. For example, although chelates of type I have thus far proved disappointing as regiospecific oxidants for alcohols, glycols, and hydroxy acids,^{3a} the Cr^{VO} Schiff's base complex VII

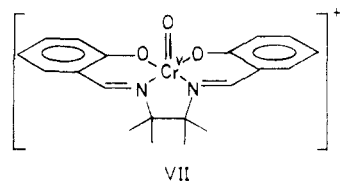

has been found^{3b,48} to oxidize olefins (to epoxides) and phosphines (to phosphine oxides) smoothly under unusually mild conditions. In addition, Cr(V) complexes constitute a fertile area for theoretically inclined workers, who have sought to reconcile the electronic

(48) Siddall, T. L.; Miyaura, N.; Huffman, J. C.; Kochi, J. K. *J. Chem. Soc., Chem. Commun.* **1983**, 1185. Complex VII is readily prepared by oxidation of the corresponding Cr(III) chelate with iodosobenzene, C₆H₅IO. Oxidations with VII can be incorporated into a catalytic cycle by using catalytic quantities of the Cr(III) precursor with stoichiometric amounts of iodosobenzene and the organic reductant.

spectra,^{4a,49} detailed ESR spectra,⁵⁰ and magnetic properties^{4b} of such compounds with orbital occupancy and ligand environment. Finally, preliminary evidence⁵ has been presented implicating Cr(V) species as carcinogens in a number of biosystems featuring interactions of ribonucleotides with added chromate.

Even more widespread attention to this unusual oxidation state is anticipated as additional investigators become aware of the ease with which it is obtained.

It is a pleasure to acknowledge the contributions of Drs. V. S. Srinivasan, N. Rajasekar, Y.-T. Fanchiang, and R. N. Bose, who carried out the work upon which a major portion of this Account is based. I am also indebted to the donors of the Petroleum Research Fund, administered by the American Chemical Society, and to the National Science Foundation for continued support of this research.

(49) See, for example: (a) Gray, H. B.; Hare, C. R. *Inorg. Chem.* **1962**, *1*, 363. (b) Milstein, J. B.; Ackerman, J.; Holt, S. L.; McGarvey, *Inorg. Chem.* **1972**, *11*, 1178.

(50) (a) Hare, C. R.; Bernal, I.; Gray, H. B. *Inorg. Chem.* **1962**, *1*, 831. (b) Greenblatt, M.; Pifer, J. H.; Banks, E. J. *J. Chem. Phys.* **1977**, *66*, 559. (c) Ziebarth, O. V.; Selbin, J. J. *Inorg. Nucl. Chem.* **1970**, *32*, 849. (d) Dalton, L. A.; Bereman, R. D.; Brubaker, C. H., Jr. *Inorg. Chem.* **1969**, *8*, 2477. (e) Garner, C. D.; Hillier, I. H.; Mabbs, F. E.; Taylor, C.; Guest, M. F. *J. Chem. Soc., Dalton Trans.* **1976**, 2258.

Small, Strained Bicycloalkyl Radicals and Some Homolytic Reactions Involving Their Parent Bicycloalkanes¹

K. U. INGOLD* and J. C. WALTON*

Division of Chemistry, National Research Council of Canada, Ottawa, Ontario, Canada, and Department of Chemistry, University of St. Andrews, St. Andrews, Scotland KY16 9ST, U.K.

Received August 14, 1985 (Revised Manuscript Received December 3, 1985)

Chemical species containing small, strained bicycloalkyl structures are interesting because the rigid framework of carbon atoms can lead to unusual and even unprecedented chemical behavior. The presence of a large amount of strain energy makes C-C bond scission a common process. Study of the regioselectivity and kinetics of homolytic decompositions and rearrangements of bicycloalkanes and bicycloalkyl radicals helps the organic chemist to understand how molecules behave when pushed toward the limits of stability. It also provides valuable data for the evaluation and calibration of the results of theoretical calculations. Additional benefits result from the discovery of novel transformations and procedures with synthetic potential.

Electron paramagnetic resonance (EPR) spectroscopy is a particularly useful technique for confirming the existence of various strained radicals that seem likely to be reaction intermediates.² It is also an ideal tech-

Keith U. Ingold received his B.Sc. degree from University College London and his D. Phil. from Oxford. He is Associate Director of the Division of Chemistry of the National Research Council of Canada. His research has concentrated on the chemistry of radicals in solution.

John C. Walton was educated at Sheffield University, where he received his B.Sc. and D.Sc. degrees and at St. Andrews University where he received his Ph.D. He joined the staff of St. Andrews University in 1969 and is now a senior Lecturer. His research interests are mainly in the area of radical chemistry.

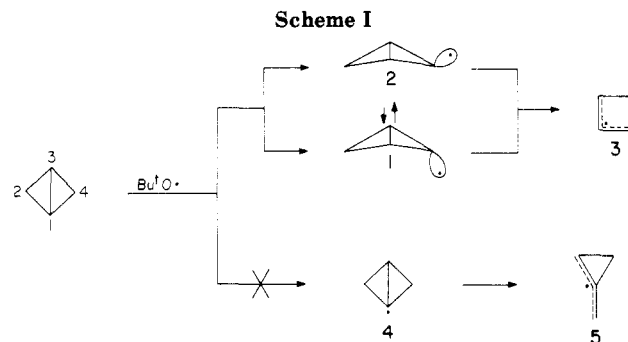

nique for revealing the distribution of spin density in radicals and hence the nature of the semioccupied molecular orbital (SOMO) and the radical's configuration and conformation.² Much of this account is therefore devoted to our EPR studies of bicycloalkyl radicals.

Hydrogen Atom Abstraction from Bicycloalkanes

Bicyclo[n.1.0]alkanes. The simplest radical from this class of hydrocarbons, bicyclo[1.1.0]but-2-yl (1), was also the first to be studied. Krusic et al.³ generated this

(1) Issued as NRCC, No. 25430.

(2) J. K. Kochi, *Adv. Free Radical Chem.*, **5**, 189 (1975).

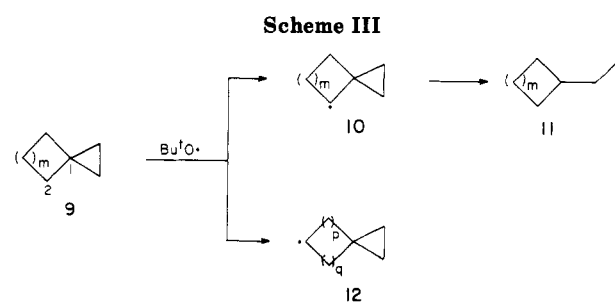
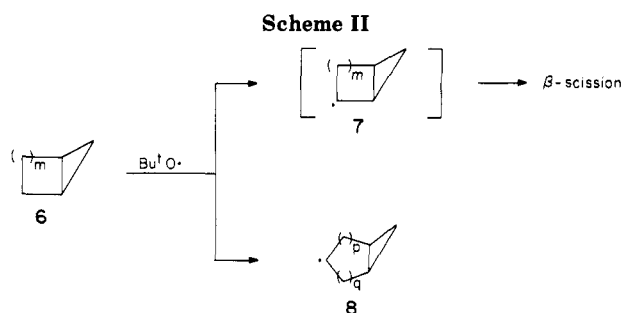

radical by H-atom abstraction from the parent butane by *tert*-butoxyl radicals directly in the cavity of an EPR spectrometer. Hydrogen abstraction occurred exclusively at the methylene position to give 1 which was detectable below 170 K (Scheme I). At higher temperatures the cyclobutenyl radical 3 was observed. Neither, the bridgehead radical, 4, nor the product of its rearrangement, i.e., 5 were detected. Our own studies of this system⁴ indicate that the rate constant for the 1 → 3 rearrangement is ca. 10³ s⁻¹ at 165 K.

The EPR hyperfine splittings (hfs) for the bicyclo[1.1.0]but-2-yl radical, viz.,²⁻⁴ $a^{\text{H}_\alpha} = 12.64$ G and $a^{\text{H}_\beta}(2\text{H}) = 4.40$ G, prove that the radical center is nonplanar, i.e., that this is a σ -radical with considerable s character in the SOMO and that it exists as the exo radical, 1. We presume that both 1 and 2 may be formed directly but that for steric reasons the endo radical, 2, will be formed somewhat more readily than 1. However, 2 will probably be less stable than 1 (because of repulsion between the H atom at the radical center and the syn H at position 4), and so it will rapidly invert to 1. Recent *ab initio* calculations⁵ indicate that 1 is 3.3 kcal/mol more stable than 2 and that the barrier for the 2 → 1 inversion is only 3.6 kcal/mol.⁶

It has been pointed out^{2,3} that the magnitude of a^{H_α} for 1 is intermediate between the values found for typical alkyl radicals (viz., -21 to -23 G) and that found for the cyclopropyl radical (viz.,¹⁰ -6.51 G). For this reason, plus the results of INDO calculations, it was concluded^{2,3} that 1 was *less* bent (i.e., more nearly planar) at its radical center than cyclopropyl. More recent calculations⁵ suggest, however, that 1 is more bent with a C_α-H_α bond out-of-plane angle of 46° vs. 39° for cyclopropyl. We suggest that the H_α hfs is positive, i.e., $a^{\text{H}_\alpha} = +12.64$ G, and that the degree of bending at its radical center is intermediate between that for cyclopropyl and that for 2,3-dimethylcyclopropen-1-yl (for which $a^{\text{H}_\alpha} = +37.0$ G).¹¹

For the higher bicyclo[*n*.1.0]alkanes, 6, we find that *tert*-butoxyl radicals abstract hydrogen exclusively from

the larger ring.^{12,13} This is readily explained by the high C-H bond strength in cyclopropane (106 kcal/mol)¹⁴ compared with cyclobutane (96 kcal/mol) or cyclooctane (94 kcal/mol).¹⁵

For bicyclo[3.1.0]hexane (6, *m* = 2) and higher homologues there is a choice of sites for H-abstraction. This can occur either from the 2-position adjacent to the cyclopropane ring (referred to hereafter as the cpm site because a cyclopropylmethyl-type of radical, 7, is formed) or from one of the other methylene groups to form a "normal" cyclic secondary alkyl radical, 8 (Scheme II). *tert*-Butoxyl attack at non-cpm sites was, however, observed only for 6 having *m* ≥ 4.¹³ For 6 having *m* = 2 and 3 (and, of course, *m* = 1)¹² attack appeared to occur exclusively at the cpm site;¹³ radicals 7 were not themselves detected because they undergo a very rapid rearrangement with opening of the cyclopropyl ring (vide infra).

In contrast to the spiro[2.*n*]alkanes (see following section) the cpm site in bicyclo[*n*.1.0]alkanes is not very significantly activated. Thus, the relative concentrations of the radicals derived by an intermolecular competitive hydrogen abstraction from 6, *m* = 1, and cyclohexane by *tert*-butoxyl radicals indicated that $k(6, m = 1)/k(\text{c-C}_6\text{H}_{12}) = 0.62$ at 323 K.¹² Similarly, in an intramolecular competition using 6, *m* = 5, the ratio for *tert*-butoxyl attack at the two cpm sites to attack at the four other secondary positions in the cyclooctane ring was 0.75 ± 0.25 at 240 K.¹⁶ For both of these samples, statistical correction for the presumed number of "available" H atoms at the different sites would suggest that there is probably a small activation of a cpm site relative to a non-cpm CH₂ group in a cycloalkane. Activation of the cpm site appears to be slightly greater for 6, *m* = 1, than for 6, *m* ≥ 4, to judge both from our EPR spectroscopic studies^{12,13} and from the fact that cyclooctane is significantly more reactive toward *tert*-butoxyl radicals than is cyclohexane.¹⁷

Spiro[*n*.*m*]alkanes. Hydrogen abstraction from spiro[2.*n*]alkanes by *tert*-butoxyl radicals also occurs from the larger ring with these hydrocarbons, but there is now a fairly strong preference for attack at the cpm site.^{16,18} This preference varies with ring size. Thus,^{16,18} for 9 with *m* = 1 and 2 attack appears to occur exclu-

(3) P. J. Krusic, J. P. Jesson, and J. K. Kochi, *J. Am. Chem. Soc.* **91**, 4566 (1969).

(4) J. C. Walton, unpublished results.

(5) J. Pacansky and M. Yoshimine, *J. Phys. Chem.*, **89**, 1880 (1985).

(6) This is similar to the barrier for inversion of the cyclopropyl⁷ and 1-methylcyclopropyl⁸ radicals. The reaction probably involves hydrogen tunneling.⁹

(7) J. K. Kochi, P. Bakuzis, and P. J. Krusic, *J. Am. Chem. Soc.* **95**, 1516 (1973). Y. Ellinger, R. Subra, B. Levy, P. Millie, and G. Berthier, *J. Chem. Phys.*, **62**, 10 (1975). M. Dupuis and J. Pacansky, *J. Chem. Phys.*, **76**, 2511 (1982). M. H. Lien and A. C. Hopkinson, *J. Comp. Chem.*, **6**, 274 (1985).

(8) L. J. Johnston and K. U. Ingold, *J. Am. Chem. Soc.*, in press.

(9) M. J. S. Dewar and J. M. Harris, *J. Am. Chem. Soc.*, **91**, 3652 (1969).

(10) R. Kaptein in "Chemically Induced Magnetic Polarization"; A. R. Lepley and G. L. Closs, Eds.; Wiley: New York, 1973; Chapter 4.

(11) R. Sutcliffe, D. A. Lindsay, D. Griller, J. C. Walton, and K. U. Ingold, *J. Am. Chem. Soc.*, **104**, 4674 (1982).

(12) C. Jamieson, J. C. Walton, and K. U. Ingold, *J. Chem. Soc., Perkin Trans. 2* **1366** (1980).

(13) C. Roberts and J. C. Walton, *J. Chem. Soc., Perkin Trans. 2* **879** (1983).

(14) M. H. Beghal-Vayjooee and S. W. Benson, *J. Am. Chem. Soc.* **101**, 2838 (1979).

(15) K. C. Ferguson and E. Whittle, *Trans. Faraday Soc.*, **67**, 2618 (1971).

(16) C. Roberts and J. C. Walton, *J. Chem. Soc., Chem. Commun.* **1109** (1984).

(17) N. J. Bunce and M. Hadley, *J. Org. Chem.* **39**, 2271 (1974).

(18) C. Roberts and J. C. Walton, *J. Chem. Soc., Perkin Trans. 2*, **841** (1985).

sively at the cpm sites, for $m = 3$ the overall ratio for attack at the (two) cpm sites to attack at the other (three) CH_2 groups was 5.8 at 240 K, and for $m = 4$ this ratio dropped to 2.3 to this temperature, but even for $m = 9$ (i.e., nine non-cpm CH_2 groups) this ratio was still 1.2 (Scheme III). Of course, these cpm sites are not quite so activated toward *tert*-butoxyl attack as are hydrogen atoms in allylic or propargylic positions (viz.,¹⁹ at 293 K k /allylic H: k /propargylic H: k /secondary H = 36:18:1). Enhanced rates of H-atom abstraction have also been observed for attack at the methyl group of methylcyclopropane.²⁰

The highest occupied of the Walsh orbitals of cyclopropane consists of a degenerate pair constructed from p-orbitals in the plane of the cyclopropane ring.²¹ In the spiro[2. n]alk-2-yl radicals, **10**, the semioccupied p-orbital at C-2 is favorably aligned with either member of this cyclopropane HOMO. The main contributions (excluding H 1s orbitals) to the resultant SOMO are shown in **13**; semiempirical calculations on the spiro-

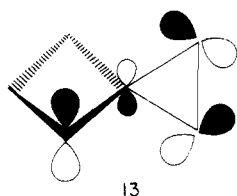

[2.3]hex-2-yl radical (**10**, $m = 1$) support this representation.¹⁸ Activation toward H-atom abstraction at the cpm site can therefore be attributed to this quasi-allyl delocalization. In bicyclo[n .1.0]alk-2-yl radicals, **7**, the axis of the semioccupied p-orbital is tilted away from an orientation parallel to the cyclopropane ring by an angle that depends on the size and conformation of the larger ring. Models based on the known conformation²² of **6**, $m = 6$, suggest that in the corresponding radical **7** the axis of the semioccupied p-orbital will be almost perpendicular to the plane of the cyclopropane ring; there will therefore be little if any cpm activation. However, for **7**, $m < 5$, the axis of the semioccupied p-orbital will become closer to the cyclopropane plane, and some cpm activation can be expected.

Spiro[2.2]pent-2-yl (**10**, $m = 0$) and spiro[2.3]hex-2-yl (**10**, $m = 1$) could be directly observed by EPR spectroscopy, but larger radicals in this class rearrange to cycloalkenylethyl radicals, **11**, too rapidly to be detected. Radical **10**, $m = 0$, was found to be a σ -radical with $|a^{\text{H}_\alpha}| = 6.2$ G, which implies a structure very similar to that of the cyclopropyl radical. Radical **10**, $m = 1$, provided a unique opportunity to observe a bicyclo cpm radical with a planar (or nearly planar) radical center. Its EPR spectrum exhibits a smaller hfs of the unpaired electron to both H_α and H_β ($a^{\text{H}_\alpha} = 19.6$ G, $a^{\text{H}_\beta}(2\text{H}) = 33.0$ G) than are found in the cyclobutyl radical (for which, $a^{\text{H}_\alpha} \approx 21.3$ G, $a^{\text{H}_\beta}(4\text{H}) = 36.8$ G).² Radical **10**, $m = 1$, shows a sizeable interaction between the un-

(19) E. Bascetta, F. D. Gunstone, and J. C. Walton, *J. Chem. Soc., Perkin Trans. 2*, 603 (1983).

(20) C. Walling and P. S. Fredricks, *J. Am. Chem. Soc.*, **84**, 3320 (1962).

(21) A. D. Walsh, *Trans. Faraday Soc.*, **45**, 179 (1949). R. Hoffmann, *J. Am. Chem. Soc.*, **90**, 1475 (1968); P. Hemmersbach and M. Klessinger, *Tetrahedron*, **36**, 1337 (1980).

(22) R. P. Corbally, M. J. Perkins, A. S. Carson, P. G. Laye, and W. V. Steele, *J. Chem. Soc., Chem. Commun.*, 778 (1978). W. G. Dauben and W. T. Wipke, *J. Org. Chem.*, **32**, 2976 (1967).

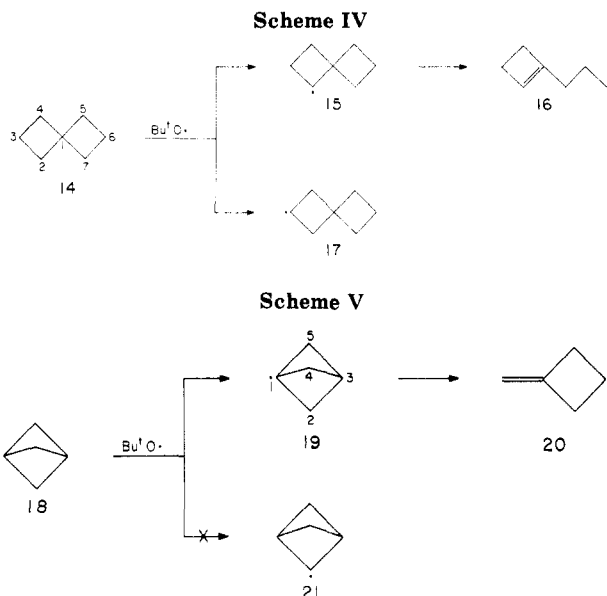

paired electron and the hydrogens on the cyclopropane ring ($a^{\text{H}_\gamma}(6\text{H}) = 1.8$ G)¹⁸ which also supports the idea of spin delocalization from an appropriately oriented cpm radical site into the three-membered ring.

tert-Butoxyl attack on spiro[3.3]heptane (**14**) yielded **15** and **17** in an approximately 2:1 ratio (Scheme IV), implying that H-atom abstraction occurs at an equal rate from each methylene group.²³ There is, therefore, no activation of the *cbm* position, nor would any have been expected. Thus, the hfs for **15**, viz.,²³ $a^{\text{H}_\alpha} = 21.2$ G and $a^{\text{H}_\beta}(2\text{H}) = 36.3$ G, are essentially the same as those for cyclobutyl (vide supra). Similarly, in photochlorinations there appears to be no activation of the methyl hydrogens of methylcyclobutane.

Bicyclo[1.1.1]pentane. This alkane, **18**, yields one of the most surprising results; both chlorine atoms²⁵ and *tert*-butoxyl radicals²⁶ abstract one of the two bridgehead methine hydrogens much more readily than one of the six bridging methylene hydrogens. Indeed, **19** was the only radical observed by EPR spectroscopy²⁶ (Scheme V). The distance between C-1 and C-3 in **19** has been calculated^{27,28} to be about 1.75 Å. Through-space (TS) interaction of the semioccupied orbital and the C-H bond at C-3 is therefore significant. Spin density can also reach H-3 via three identical through-bond (TB) routes, each involving two C-C bonds. For each TB route the semioccupied orbital and the C-H bond at C-3 are essentially in the ideal, all-trans (W-plan) arrangement. Theory²⁹ predicts that TS and TB interactions will reinforce one another when the TB interaction occurs through two bonds. In agreement with our expectations, the EPR spectrum of **19** exhibited an enormous hfs of 69.6 G for the unique bridgehead γ -hydrogen.²⁶ The magnitude of this hfs suggests

(23) C. Roberts, J. C. Walton, and B. Maillard, *J. Chem. Soc., Perkin Trans. 2*, 305 (1986).

(24) J. M. Tedder and J. C. Walton, *Adv. Free Radical Chem.*, **6**, 155 (1980).

(25) K. B. Wiberg and V. Z. Williams, *J. Org. Chem.*, **35**, 369 (1970).

(26) B. Maillard and J. C. Walton, *J. Chem. Soc., Chem. Commun.*, 900 (1983).

(27) M. Ohsaku, A. Imamura, K. Hirao, and T. Kawamura, *Tetrahedron*, **35**, 701 (1979).

(28) J. R. Bews, C. Glidewell, and J. C. Walton, *J. Chem. Soc., Perkin Trans. 2*, 1447 (1982).

(29) M. N. Paddon-Row, *Acc. Chem. Res.*, **15**, 245 (1982). J. W. Verhoeven, *Recl. Trav. Chim. Pays-Bas.*, **99**, 369 (1980).

that there is ca. 14% spin delocalization onto the hydrogen attached to C-3 which helps to explain both the faster rate of hydrogen abstraction from the bridgehead position and the relatively easy formation of [1.1.1]propellane (22).³⁰



Rearrangements of Bicycloalkyl and Spiroalkyl Radicals

β -Scission in strained alkyl radicals normally occurs readily if the reaction is exothermic and if the SOMO can assume an eclipsed conformation with respect to the β - γ -bond.³¹ Stereoelectronics provides a simple explanation for the reluctant ring opening of cyclopropyl radicals³² and for the rapid ring-opening of cyclopropylcarbinyl radicals.³³

Bicyclo[$n.1.0$]alk-2-yl radicals, **7**, all undergo rapid ring-opening. However, there is a sharp division between radicals **7**, $m = 0$, and **7**, $m = 1$, on the one hand, which yield the thermodynamically more stable cycloalkenyl radicals **23**, and the larger radicals **7**, $m \geq 2$, which rearrange to cycloalkenylmethyl radicals, **24** (see Scheme VI).^{12,13} Probably the most remarkable fact about **7**, $m = 0$, is that it can be observed by EPR spectroscopy. These radicals contain ca. 67 kcal/mol strain energy, yet they are sufficiently stable to be observed at low temperatures.²⁻⁴ They are simultaneously both cyclopropyl-type and cyclopropylmethyl-type radicals. β -Scission leads exclusively to the cyclobutenyl radical **23**, $m = 0$. That is, it is the inter-ring bond which cleaves and so **7**, $m = 0$, behaves like a cyclopropyl radical insofar as ring-opening is concerned and not like a cyclopropylmethyl radical. The product of the latter type of ring-opening, mode 2, i.e., cyclopropenylmethyl **24**, $m = 0$, would be highly strained and for this reason mode 1 ring-opening is preferred (vide infra). Because the SOMO in **7**, $m = 0$, is orthogonal to the inter-ring bond, the ring-opening is stereoelectronically disfavored, which gives this radical a sufficient lifetime for its observation.

For bicyclo[2.1.0]pent-2-yl radicals, **7**, $m = 1$, mode 1 ring scission would yield **23**, $m = 1$, and mode 2 **24**, $m = 1$. The latter radical could undergo a second β -scission to give the pentadienyl radical **25**. In **7**, $m = 1$, the SOMO can more readily eclipse the outer cyclopropane C-C bond than in **7**, $m = 0$, and for this reason a mode 2 rearrangement synchronous with the formation of **25** might have been expected. Such a "double-barreled" rearrangement would relieve *all* ring strain and would result in a gain of 24 kcal/mol³⁴ of stabilization energy for the final pentadienyl radical.

It was therefore rather surprising to find¹² both by product studies and by EPR spectroscopy that mode 1 rearrangement occurred exclusively. (Incidentally,

(30) K. B. Wiberg and F. H. Walker, *J. Am. Chem. Soc.* **104**, 5239 (1982).

(31) A. L. J. Beckwith and K. U. Ingold In "Rearrangements in Ground and Excited States"; P. de Mayo, Ed.; Academic Press: New York, 1980; Vol. 1, p 161.

(32) J. T. Groves and K. W. Ma, *J. Am. Chem. Soc.*, **96**, 6527 (1974); K. Herwig, P. Lorenz, and C. Rüchardt, *Chem. Ber.*, **108**, 1421 (1975).

(33) B. Maillard, D. Forrest, and K. U. Ingold, *J. Am. Chem. Soc.*, **98**, 7024 (1976). A. Effio, D. Griller, K. U. Ingold, A. L. J. Beckwith, and A. K. Serelis, *J. Am. Chem. Soc.*, **102**, 1734 (1980).

(34) J. C. Walton, *Rev. Chem. Intermed.*, **5**, 249 (1984).

Scheme VI

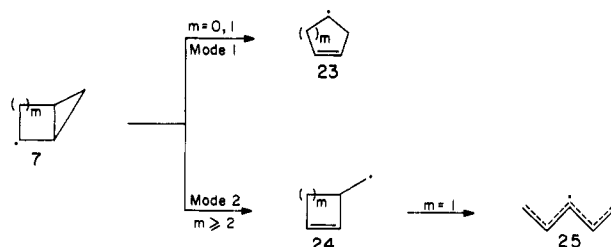

this particular reaction provides a method for the preparation of 4-substituted cyclopentenes.) The dominance of the mode 1 rearrangement can be attributed to the fact that **7**, $m = 1$, cannot "see" that the most stabilized product it could form is **25**. Thus, **7**, $m = 1$, could not be detected by ER spectroscopy; rearrangement to **23**, $m = 1$, was complete at -160°C , and hence the activation energy for the inter-ring bond scission is ≤ 6 kcal/mol.¹²

Cyclobutenylmethyl radicals **24**, $m = 1$, on the other hand do not rearrange under EPR conditions until $T \geq \text{ca. } -30^\circ\text{C}$, and the activation energy for this process is 10.1 kcal/mol.³⁵ Therefore, if **24**, $m = 1$, lies on the **7**, $m = 1$, to **25** reaction coordinate, the ring strain cannot be relieved all at one time, and a 10 kcal/mol barrier must be traversed to achieve this transformation. There is much less relief of strain on going from **7**, $m = 1$ to **24**, $m = 1$, than in going from **7**, $m = 1$ to **23**, $m = 1$ (vide infra), and so the latter route is preferred.

Despite its favorable energetics the mode 1 rearrangement of **7**, $m = 1$, would be expected to have a high activation energy *unless* there was appreciable overlap between its SOMO and the inter-ring bond. While a simple drawing of this radical would suggest that the SOMO is orthogonal to the C-1 to C-4 inter-ring bond it is known that this bond is intermediate in length between that of the C-C bonds in cyclopropane and cyclobutane.³⁶ This implies that the C-1 to C-4 bond in **7**, $m = 1$, is formed from orbitals having excess p-character resulting in a bent bond (see **26**), which would overlap to some extent with the SOMO.

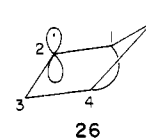

EPR studies of the higher homologues of **7** with $m \geq 2$ showed that the mode 2 rearrangement to **24** predominates in all cases.¹³ The activation energies for this rearrangement are ≤ 6 kcal/mol.¹³ Product studies³⁷ on **6**, $m = 2$ and $m = 3$, are basically in agreement with the EPR results although the former compound did give some products derived from the mode 1 rearrangement. Models indicate that the SOMO for **7**, $m \geq 2$, can overlap the inter-ring bond when the large ring adopts a boat conformation but that all other conformations favor overlap with the outer cyclopropane bond. Since boat conformations are unlikely to be important³⁷

(35) K. U. Ingold, B. Maillard, and J. C. Walton, *J. Chem. Soc., Perkin Trans. 2*, 970 (1981).

(36) R. D. Suenram and M. D. Harmony, *J. Chem. Phys.*, **56**, 3837 (1972). S. N. Mathur and M. D. Harmony, *J. Chem. Phys.*, **64**, 4340 (1976).

(37) E. C. Friedrich and R. L. Holmstead, *J. Org. Chem.*, **37**, 2550 (1972).

Table I.
Estimated Relief of Ring Strain (kcal/mol) in the
Rearrangements of Bicyclo[*n*.1.0]alk-2-yl Radicals, 7, *m* =
0–5^a

<i>m</i>	mode 1	mode 2
	RS 23–RS 7	RS 24–RS 7
0	37	13
1	49	26
2	31	27
3	23	28
4	24	24
5	21	25

^a Based on the RS values of the corresponding hydrocarbons.³⁸

stereoelectronic factors favor the mode 2 rearrangements.

Although the ring-strain energies (RS) of radicals 7, 23, and 24 are probably slightly less than those of their parent hydrocarbons (which are known)³⁸ it seems reasonable to estimate roughly the relief of ring strain involved in the two modes of β -scission on the basis of the RS values of the hydrocarbons. These data are given in Table I. It can be seen that for 7, *m* = 1 and *m* = 2, the mode 1 rearrangement is energetically strongly favored. However, this is not the case for 7, *m* \geq 2, which follow instead the mode 2 rearrangement, presumably largely for stereoelectronic reasons.

A very interesting study by Sustmann and Lubbe³⁹ described the rearrangement of the bicyclo[3.1.0]hexenyl radical 27 in an adamantane matrix. This radical could be observed at low temperatures, but it rearranged to the cyclohexadienyl radical 28 at temperatures above -60°C . Clearly this rearrangement occurs

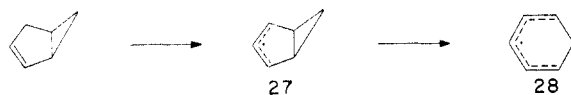

by scission of the inter-ring bond. Deuterium-substituted radicals such as 29 were found to give cyclohexadienyl radicals in which the deuterium atom was statistically distributed over the pentadienyl moiety. This points to a circumambulation by the methylene unit that occurs by a degenerate rearrangement involving scission of one of the outer cyclopropane bonds in 29 to give 30 (see Scheme VII). The free energy of activation for the circumambulation must be less than that for cyclohexadienyl radical formation (for which $\Delta G^\ddagger = 14$ kcal/mol). For stereoelectronic reasons the scission of the outer cyclopropane bond occurs more readily than scission of the inner bond in 29 as in 7, *m* = 2. This deuterium-labeling experiment showed that the ring opening of the bicyclo[3.1.0]hexenyl radical 27 is analogous to that of the bicyclo[3.1.0]hexyl radical, (7, *m* = 2; Scheme VI), even though the initial data seemed to indicate otherwise.

Spiro[2.*n*]alk-2-yl radicals, 10, undergo β -scission to form cycloalkenylethyl radicals 11 (Scheme III). EPR observations showed that the first member of this series, the spirocyclopentyl radical 10, *does not undergo ring-opening at room temperature in solution*,⁴⁰ while

(38) S. W. Benson, "Thermochemical Kinetics", 2nd ed.; Wiley: New York, 1976; p 273.

(39) R. Sustmann and F. Lubbe, *J. Am. Chem. Soc.*, **98**, 6037 (1976); *Tetrahedron Lett.*, 2831 (1974); *Chem. Ber.*, **112**, 42 (1979). For some other interesting rearrangements of matrix isolated bicyclic radicals, see: R. Sustmann, D. Brandes, F. Lange, and U. Nüchter, *Chem. Ber.*, **118**, 3500 (1985).

Table II.
Kinetics of β -Scission in Spiro[2.*n*]alk-2-yl Radicals, 9, *m* =
0–3

<i>m</i>	$k(25^\circ\text{C})/\text{s}^{-1}$	$\log A/\text{s}^{-1}$ ^a	E^b	RS 11–RS 10 ^{b,c}
0	$<10^4$	[13]	>12	10
1	1.1×10^7	12.5	7.2	24
2	$>10^{8.5}$	[13]	<6.5	28
3	$>10^{8.5}$	[13]	<6.5	26

^a Assumed values in brackets. ^b In kcal/mol. ^c Based on the RS values of the corresponding hydrocarbons.³⁸

Scheme VII

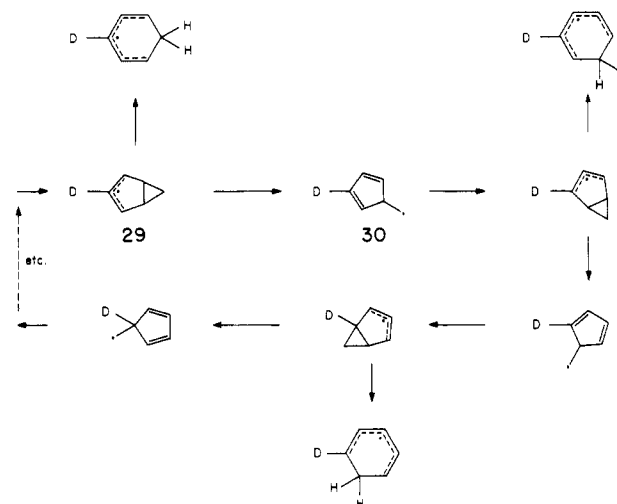

product studies have indicated that this radical remains intact even at 116°C in the gas phase.⁴¹ This is truly surprising because there is obviously very great strain in this radical (ca. 63.5 kcal/mol in 9, *m* = 0).³⁸ The next radical in this series, 10, *m* = 1, rearranges at ca. -110°C , while the higher homologues with *m* = 2 and 3 cannot even be detected by EPR spectroscopy because they are fully rearranged to 11 at the lowest accessible temperatures. Some kinetic data for these reactions are given in Table II. The dramatic increase in reaction rate with increasing ring size parallels the increasing exothermicities of the reactions. The β -scission of the spirocyclopentyl radical 10, *m* = 0, is fairly strongly exothermic, but the reaction is remarkably slow, suggesting that it is disfavored by some factor. Alone of the spiro[2.*n*]alkyl radicals 10, *m* = 0 is a σ -radical with consequent poor (perhaps negligible) overlap of the SOMO with the β - γ -bond. We attribute the remarkable structural integrity of this radical to this factor. The higher homologues are π -radicals with planar radical centers and their SOMO's can overlap with the β - γ -bond without difficulty. They are therefore much less stable than spirocyclopentyl.

The spiro[3.3]hept-2-yl radical (15) rearranges to the cyclobutenylpropyl radical 16 (Scheme IV), but this process occurs appreciably more slowly than the β -scission of cyclobutylmethyl radical,²³ its monocyclic analogue. The rigid structure of 15 prevents the SOMO from achieving maximum overlap with the β - γ -bond, but there is no such restriction in the cyclobutylmethyl radical. Furthermore, the relief of ring strain in the β -scission of 15 is less than for cyclobutylmethyl, be-

(40) A. J. Kennedy, J. C. Walton, and K. U. Ingold, *J. Chem. Soc., Perkin Trans. 2*, 751 (1982).

(41) D. E. Applequist, G. F. Fanta, and B. W. Henrikson, *J. Am. Chem. Soc.*, **82**, 2368 (1960).

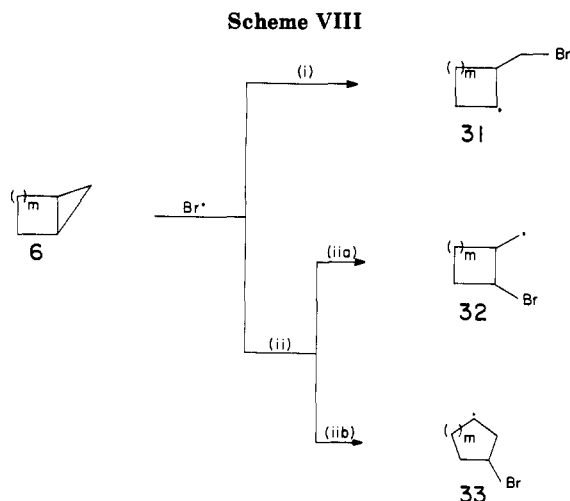

cause the rearranged radical 16 contains the cyclobutenyl ring.

Bimolecular Homolytic Substitution Reactions Involving Bicycloalkanes

Halogen atoms induce homolytic ring cleavage in cyclopropane, i.e., this reaction is a bimolecular homolytic substitution or $S_{\text{H}}2$ process.^{24,42} Photochlorinations, -brominations, and -iodinations of bicycloalkanes have been investigated. The "cleanest" reaction is generally the photobromination. The bromine atom may attack a bicyclo[*n*.1.0]alkane, 6, at either (i) the bridge methylene group with consequent cleavage of an outer cyclopropane bond to form 31 or (ii) the bridgehead methine carbon with cleavage of the outer cyclopropane bond to give 32, i.e. iia, or of the inter-ring bond to give 33, i.e. iib, (see Scheme VIII).

Bromine atoms react with both bicyclo[1.1.0]butane (6, *m* = 0) and bicyclo[2.1.0]pentane (6, *m* = 1) by attacking at the bridgehead position exclusively, reaction ii, and this is followed by inter-ring bond cleavage, reaction iib, to form substituted cyclobutanes and cyclopentanes, respectively.^{12,43} In the higher homologues, 6, *m* ≥ 2, both inter-ring and outer cyclopropane bond scission occur,^{13,44,45} but we could not determine the relative rates of attack at the bridgehead and bridge positions because both 32 and 31 yield the same dibromide product. However, the ratios of outer to inter-ring bond scission, i.e., [(i) + (iia)]/(iib), could be determined from the dibromide yield; this ratio rose from zero for 6, *m* = 0 and *m* = 1, to 0.6 and 6.3 for 6, *m* = 2 and *m* = 3, respectively.¹³ This changeover from predominant inter-ring cleavage to predominant outer cyclopropane bond cleavage with increasing ring size

(42) K. U. Ingold and B. P. Roberts, "Free Radical Substitution Reactions"; Wiley: New York, 1971.

(43) R. S. Boikess and M. D. Mackay, *Tetrahedron Lett.*, 5991 (1968); *J. Org. Chem.*, **36**, 901 (1971). K. B. Wiberg, G. M. Lampman, R. P. Ciula, D. S. Connor, P. Schertler, and J. Lavanish, *Tetrahedron*, **21**, 2749 (1965).

(44) P. K. Freeman, F. A. Raymond, J. C. Sutton, and W. R. Kindley, *J. Org. Chem.*, **33**, 1448 (1968). R. S. Boikess, M. D. Mackay, and D. Bliethe, *Tetrahedron Lett.*, 401 (1971).

(45) In these higher homologs minor amounts of monobromides are also produced, presumably by H-atom abstraction from the larger ring. The importance of this process increases with increasing ring size.

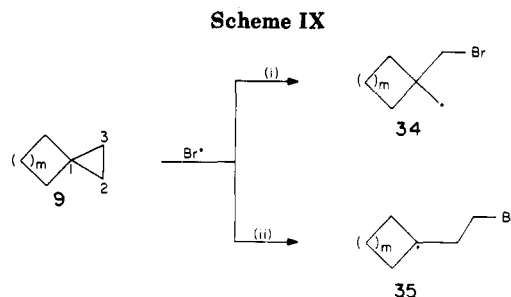

closely parallels the same changeover which was observed in the β -scission of the bicyclo[*n*.1.0]alk-2-yl radicals, 7. We attribute both changeovers to changes in ring strain. The ring strain released by inter-ring bond scission decreases sharply from 6, *m* = 1, to 6, *m* = 3, while the ring strain released by outer bond scission increases slightly (see Table I).

The $S_{\text{H}}2$ reaction of halogen atoms with spiro[2.*n*]alkanes, 9, probably involves exclusive attack at a methylene group of the cyclopropane ring. Once again, two types of cleavage are possible (see Scheme IX). With spiro[2.3]hexane 9, *m* = 0, both chlorination^{41,46} and bromination⁴⁰ lead predominantly to cleavage of the C-2 to C-3 bond, i.e., type i cleavage. Thus, with Br• at 300 K the products indicate that $k(\text{i})/k(\text{ii}) \sim 1,000$. In contrast, the bromination of spiro[2.3]hexane (9, *m* = 1) leads to predominant cleavage of the C-1 to C-2 bond; $k(\text{i})/k(\text{ii}) = 0.4$ at 300 K.¹⁸ These results fit into the pattern established for the photobromination of alkyl-substituted cyclopropanes in which ring scission always favors the generation of the more stabilized alkyl radical,⁴⁷ i.e., the cyclopropyl-type radical 35, *m* = 0 will be *less* stable than the primary alkyl radical 34, *m* = 0, but the cyclobutyl-type radical 35, *m* = 1, will be *more* stable than the primary alkyl 34, *m* = 1. These $S_{\text{H}}2$ reactions were the only detectable processes for the photobromination of 9, *m* = 0 and *m* = 1, but a small amount of H-atom abstraction occurred in the photochlorinations.

Conclusion

Our studies of the homolytic reactions of small, strained bicycloalkanes and of the radicals derived from them has revealed a rich chemistry in which the direction taken by particular reactions, and radical stabilities are determined by a complex interplay between ring strain and stereoelectronic (orbital overlap) effects. Of course, ring strain and stereoelectronics are both well-recognized phenomena in radical chemistry, but only the former has been reasonably well characterized in thermodynamic terms. We believe that the chemistry of those small, strained bicycloalkyl radicals in which ring strain and stereoelectronics operate in competition will provide a unique opportunity to put stereoelectronic effects onto a firm and quantitative footing. "What's past is prologue".⁴⁸

(46) D. E. Applequist and J. E. Landgrebe, *J. Am. Chem. Soc.*, **86**, 1543 (1964).

(47) K. J. Shea and P. S. Skell, *J. Am. Chem. Soc.*, **95**, 6728 (1973).

(48) W. Shakespeare, "The Tempest"; Act II.